

Think BIBLICALLY

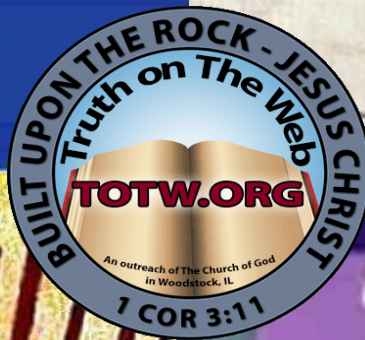

RENEW

your mind
Romans 12:2

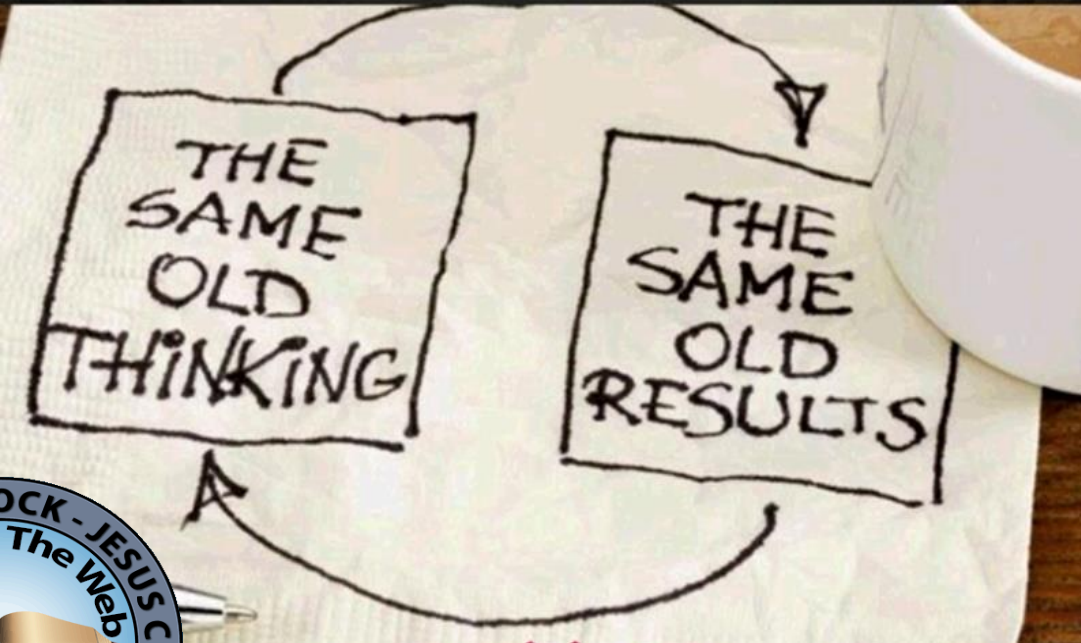

One Bread, One Body



1 Corinthians 10:15-17 I speak as to wise men; judge ye what I say. The cup of blessing which we bless, is it not the communion of the blood of Christ? The bread which we break, is it not the communion of the body of Christ? For **we being many are one bread, and one body**: for we are all partakers of that one bread.

PASSOVER Blessings!

URGENT

1st
century
CIRCA ROMA



1 Corinthians

1 Corinthians 8:1-3 Now as touching things offered unto idols, we know that we all have knowledge. Knowledge puffeth up, but charity edifieth. And if any man think that he knoweth any thing, he knoweth nothing yet as he ought to know. But if any man love God, the same is known of Him.

Jeremiah 9:23-24 Thus saith the LORD, Let not the wise *man* glory in his wisdom, neither let the mighty *man* glory in his might, let not the rich *man* glory in his riches: But let him that glorieth glory in this, that he understandeth and knoweth Me, that I *am* the LORD which exercise lovingkindness, judgment, and righteousness, in the earth: for in these *things* I delight, saith the LORD.

1 John 4:20-21 If a man say, I love God, and hateth his brother, he is a liar: for he that loveth not his brother whom he hath seen, how can he love God whom he hath not seen? And this commandment have we from him, That he who loveth God love his brother also.

Romans 12:5 So we, being many, are one body in Christ, and every one members one of another.

1 Corinthians 12:27 Now ye are the body of Christ, and members in particular.

John 17:11 And now I am no more in the world, but these are in the world, and I come to Thee. Holy Father, keep through Thine own name those whom Thou hast given Me, **that they may be one, as We are.**

John 17:20-23 Neither pray I for these alone, but for them also which shall believe on Me through their word; **That they all may be one; as Thou, Father, art in Me, and I in Thee, that they also may be one in Us:** that the world may believe that Thou hast sent Me. And the glory which Thou gavest Me I have given them; **that they may be one, even as We are one: I in them, and Thou in Me, that they may be made perfect in one;** and that the world may know that Thou hast sent Me, and hast loved them, as Thou hast loved Me.

2 Corinthians 5:18-19 And all things are of God, Who hath reconciled us to Himself by Jesus Christ, and **hath given to us the ministry of reconciliation**; To wit, that God was in Christ, reconciling the world unto Himself, not imputing their trespasses unto them; and **hath committed unto us the word of reconciliation.**

John 15:17 These things I
command you, that ye love one
another.

John 13:34-35 A new
commandment I give unto you,
That ye **love one another; as I
have loved you, that ye also
love one another.** By this shall
all men know that ye are My
disciples, if ye have love one to
another.

John 15:12-13 This is My
commandment, **That ye love
one another, as I have loved
you.** Greater love hath no man
than this, that a man lay down
his life for his friends.

1 Corinthians 13:4-7 Love is patient and is kind; love doesn't envy. Love doesn't brag, is not proud, doesn't behave itself inappropriately, doesn't seek its own way, is not provoked, takes no account of evil; doesn't rejoice in unrighteousness, but rejoices with the truth; bears all things, believes all things, hopes all things, endures all things.

1 Corinthians 1:10-13 Now I beseech you, brethren, by the name of our Lord Jesus Christ, that ye all speak the same thing, and that there be no divisions among you; but that ye be perfectly joined together in the same mind and in the same judgment. For it hath been declared unto me of you, my brethren, by them which are of the house of Chloe, that there are contentions among you. Now this I say, that every one of you saith, I am of Paul; and I of Apollos; and I of Cephas; and I of Christ. Is Christ divided? was Paul crucified for you? or were ye baptized in the name of Paul?

1 Corinthians 3:3-4 For ye are yet carnal: for whereas there is among you envying, and strife, and divisions, are ye not carnal, and walk as men? For while one saith, I am of Paul; and another, I am of Apollos; are ye not carnal?

Romans 14:1-4 Him that is weak in the faith receive ye, but not to doubtful disputations. For one believeth that he may eat all things: another, who is weak, eateth herbs. Let not him that eateth despise him that eateth not; and let not him which eateth not judge him that eateth: for God hath received him. Who art thou that judgest another man's servant? to his own master he standeth or falleth. Yea, he shall be holden up: for God is able to make him stand.

Now receive one who is weak in faith, but not for disputes over opinions. WEB

Welcome the person who is weak in faith—but not in order to argue about differences of opinion. CEV

Accept the one whose faith is weak, without quarreling over disputable matters. NIV

Be willing to accept those who still have doubts about what believers can do. And don't argue with them about their different ideas. ERV

THE GREAT

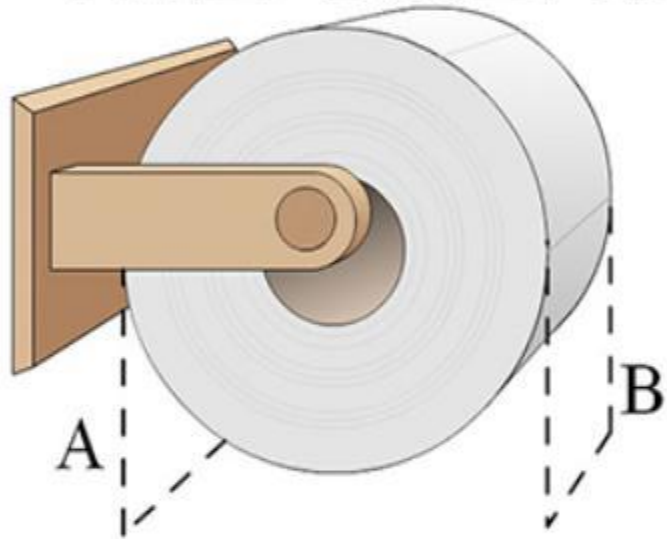

DEBATE

Disputable matters
wherein the Scripture
does not require
adherence one way
or the other) . They
do not apply to
requirements of law.

i.e., Romans 14 & 15

(No Model.)

S. WHEELER.
TOILET PAPER ROLL.

No. 465,588.

Patented Dec. 22, 1891

Fig. 1.

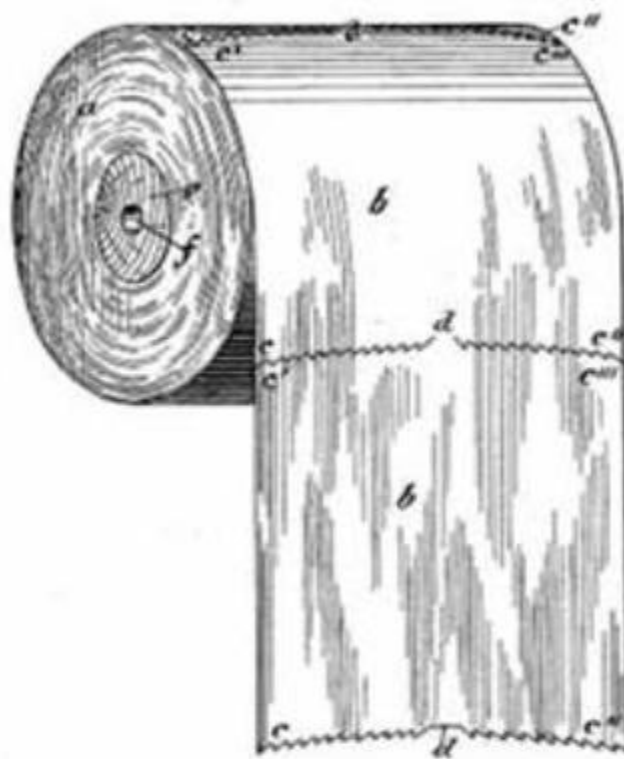

Fig. 2.



WITNESSES:
John Beecher

INVENTOR:
S. Wheeler

Romans 14:13-15 Let us not therefore judge one another any more: but judge this rather, that no man put a stumblingblock or an occasion to fall in his brother's way. I know, and am persuaded by the Lord Jesus, that there is nothing unclean of itself: but to him that esteemeth any thing to be unclean, to him it is unclean. But if thy brother be grieved with thy meat, now walkest thou not charitably. Destroy not him with thy meat, for whom Christ died.

Romans 14:19-23 Let us therefore follow after the things which make for peace, and things wherewith one may edify another. For meat destroy not the work of God. All things indeed are pure; but it is evil for that man who eateth with offence. It is good neither to eat flesh, nor to drink wine, nor any thing whereby thy brother stumbleth, or is offended, or is made weak. Hast thou faith? have it to thyself before God. Happy is he that condemneth not himself in that thing which he alloweth. And he that doubteth is damned if he eat, because he eateth not of faith: for whatsoever is not of faith is sin.

Romans 15:1-7 We then that are strong ought to bear the infirmities of the weak, and not to please ourselves. Let every one of us please his neighbour for his good to edification. For even Christ pleased not Himself; but, as it is written, The reproaches of them that reproached thee fell on me. For whatsoever things were written aforetime were written for our learning, that we through patience and comfort of the Scriptures might have hope. Now the God of patience and consolation grant you to be likeminded one toward another according to Christ Jesus: That ye may with one mind and one mouth glorify God, even the Father of our Lord Jesus Christ. Wherefore receive ye one another, as Christ also received us to the glory of God.

Romans 16:17-18 Now I beg you, brothers, look out for those who are causing the divisions and occasions of stumbling, contrary to the doctrine which you learned, and turn away from them. For those who are such don't serve our Lord, Jesus Christ, but their own belly; and by their smooth and flattering speech, they deceive the hearts of the innocent.

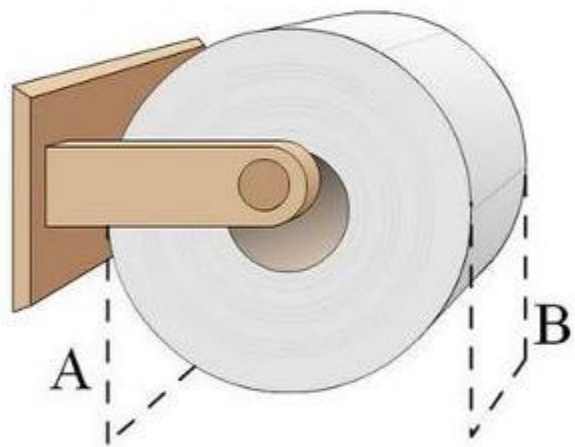

or



לא תרצח
לא תנאף
לא תנוב
לא תענה
לא תחמוד

אבני יהוה
לא יהוה
לא תשא את
שבוד את הוה
סבד את אבני

Luke 22:24-27 And there was also a strife among them, which of them should be accounted the greatest. And He said unto them, The kings of the Gentiles exercise lordship over them; and they that exercise authority upon them are called benefactors. But ye shall not be so: but he that is greatest among you, let him be as the younger; and he that is chief, as he that doth serve. For whether is greater, he that sitteth at meat, or he that serveth? is not he that sitteth at meat? but I am among you as he that serveth.

John 13:3-5 Jesus knowing that the Father had given all things into His hands, and that He was come from God, and went to God; He riseth from supper, and laid aside His garments; and took a towel, and girded Himself. After that He poureth water into a bason, and began to wash the disciples' feet, and to wipe them with the towel wherewith He was girded.

John 13:12-17 So after He had washed their feet, and had taken His garments, and was set down again, He said unto them, Know ye what I have done to you? Ye call Me Master and Lord: and ye say well; for so I am. If I then, your Lord and Master, have washed your feet; ye also ought to wash one another's feet. For I have given you an example, that ye should do as I have done to you. Verily, verily, I say unto you, The servant is not greater than his lord; neither he that is sent greater than he that sent him. If ye know these things, happy are ye if ye do them.

1 Corinthians 10:32-33 Give none offence, neither to the Jews, nor to the Gentiles, nor to the church of God: Even as I please all men in all things, not seeking mine own profit, but the profit of many, that they may be saved.

Ephesians 4:1-3 I therefore, the prisoner of the Lord, beseech you that ye **walk worthy of the vocation wherewith ye are called**, With all lowliness and meekness, with longsuffering, forbearing one another in love; Endeavouring to keep the unity of the Spirit in the bond of peace.

Philippians 2:1-4 If there be therefore any consolation in Christ, if any comfort of love, if any fellowship of the Spirit, if any bowels and mercies, Fulfil ye my joy, that ye be likeminded, having the same love, being of one accord, of one mind. Let nothing be done through strife or vainglory; but in lowliness of mind let each esteem other better than themselves. Look not every man on his own things, but every man also on the things of others.

2 Timothy 2:24-26 And the servant of the Lord must not strive; but be gentle unto all men, apt to teach, patient, In meekness instructing those that oppose themselves; if God peradventure will give them repentance to the acknowledging of the truth; And that they may recover themselves out of the snare of the devil, who are taken captive by him at his will.

Ephesians 2:13-15 But now in Christ Jesus ye who sometimes were far off are made nigh by the blood of Christ. For He is our peace, who hath made both one, and hath broken down the middle wall of partition between us; Having abolished in his flesh the enmity, even the law of commandments contained in ordinances; for to make in himself of twain one new man, so making peace;

1 Thessalonians 5:14-15 Now we exhort you, brethren, warn them that are unruly, comfort the feebleminded, support the weak, be patient toward all men. See that none render evil for evil unto any man; but ever follow that which is good, both among yourselves, and to all men.

1 Peter 1:22 Seeing ye have purified your souls in obeying the truth through the Spirit unto **unfeigned love** of the brethren, **see that ye love one another with a pure heart fervently:**

Seek His holy will!

HAPPY FEAST
DAY!

KEEP IT HOLY!

*Sabbath4CoGs
Chatroom*

**Thy
Word
is
Truth**

John 17:17



Truth On The Web Ministries



Eph 6:17 And take..the sword of the
spirit, which is the word of God.



THANK YOU!!

Church of God at Woodstock

HAPPY FEAST
DAY!

KEEP IT
WHOLLY!

HAPPY FEAST
DAY!

KEEP IT HOLY!

HAPPY FEAST
DAY!