

# I AM RESOLVED

Music to the Soul

ritard. (a tempo)



**TRUTH ON THE  
WEB MINISTRIES**

**[WWW.TOTW.ORG](http://WWW.TOTW.ORG)**

EPH 6:17 AND TAKE...THE SWORD OF THE  
SPIRIT WHICH IS THE WORD OF GOD  
A CHURCH OF GOD IN WOODSTOCK, ILLINOIS

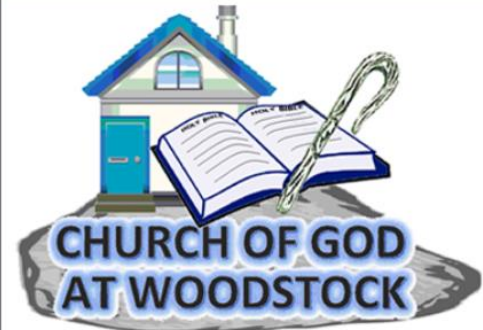

I AM RESOLVED

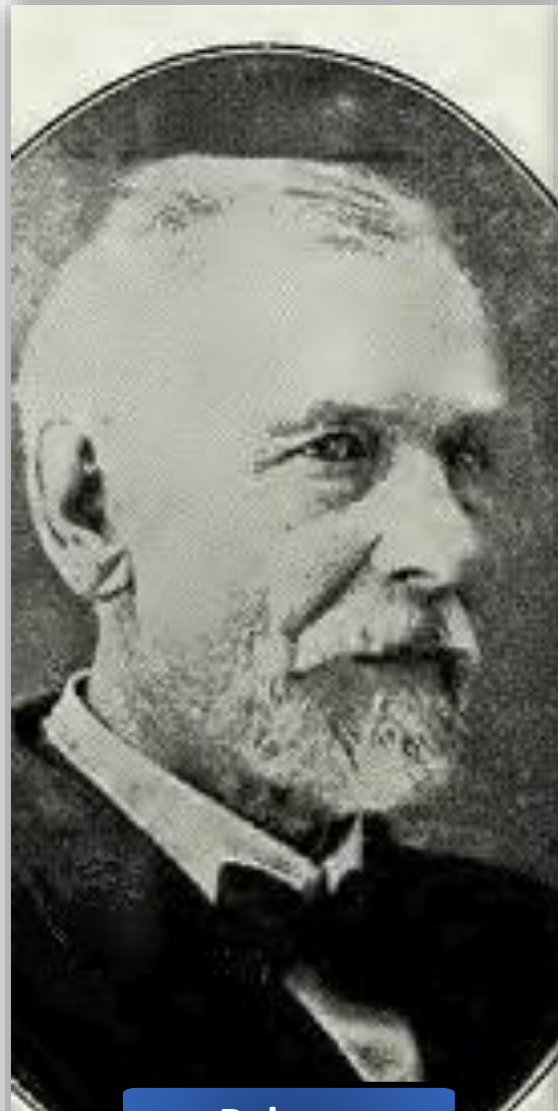

Palmer Hartsough

I Am Resolved

re - solved no long - er to lin - ger, charmed by the  
 re - solved to go to the Sav - ior, leav - ing my  
 re - solved to fol - low the Sav - ior, faith - ful and  
 re - solved to en - ter the king - dom, leav - ing the  
 re - solved, and who will go with me? Come, friends, wit

are high - er, things that are no - bler, These have  
 the true one, He is the just one, He hath t  
 He say - eth, do what He will - eth; He is t  
 op - pose me, foes may be - set me; Still will  
 the Bi - ble, led by the Spir - it, We'll walk t

will has - ten to Him, Has - ten so glad and free;  
 I has - ten, has - ten to Him,

- sus, Great - est, High - est, I will  
 sus, Je - sus,



James H. Fillmore

844-1932

Jan

# I AM RESOLVED

1. All Safe to Land
2. All Thy Hills He Clothed with Fating
3. Along the Ancient Highway
4. [Are You Sowing the Seed?](#)
5. Are You Trusting in the Savior?
6. Armies of Zion
7. As Goes America, So Goes the World
8. As We Joyful Gather in This Happy Band
9. Banners Waving Proudly o'er Us
10. Be Not Afraid, But Speak
11. Beautiful Flag of Liberty
12. Beautiful River of Life
13. Behold, a Stranger Waiting Stands
14. Behold, Behold the Fields Already White
15. Bells Are Ringing, Birds Are Singing
16. Bells of Heaven, How They Gently Chime
17. Brief Day of Life Is Fast Nearing Its Close, The
18. Bright Bloom the Daisies
19. Bright Hosts in Worlds Above
20. Bright Star of Hope
21. Bring Me Not Gifts
22. [Cheerful Giving](#)
23. Chiming Through the Azure Sky
24. Christ, Our Friend, O What a Wonder
25. Clear on Earth's Gloomy Night
26. Come Out, Come Out, Good Girls and Boys
27. Come to the Lord in Prayer
28. Come to the Savior
29. Conquering Christ, O Earth, Behold, The
30. Dark Is the Night
31. Ever for the Right, Boys
32. Eye Hath Not Seen
33. [Fair Lilies We Bring You](#)
34. Father in Heaven So Kindly Doth Give, The
35. Father, Kind, Above, Sent Forth in Tender Love, The
36. Father, Pleads Thy Son in Prayer
37. Filled with the Spirit Sent From the Father
38. Flowers of the Field Have a Lesson for Me, The
39. Fly Your Banners
40. Follow in the Path Where Jesus Leads
41. Following Jesus, Shepherd Divine
42. Following the Steps of Jesus
43. For the Ones That Are Dear
44. Forward, Forward, Forward Go
45. From a Distant Shore Comes the Moaning Cry
46. Give, Give to the Lord Saith the Word
47. Give Thanks to the Lord, and Bless His Name
48. Give We Praise to the God Above
49. Glory So Great, The
50. Go Forth, Thou Church Triumphant
51. God Bless Our Native Land
52. Grant Us, Lord, Thy Blessed Favor
53. Great Joy in That City
54. Greet the Whole World with a Smile
55. Hail, Mighty Victor, Hail
56. Happy in the Gospel From Above
57. Has the Promise of the Father
58. He Is Coming
59. Hear the Trumpet Call That's Sounding
60. Hear Ye Not the Trumpet Blast?
61. Heaven, Sweet Heaven, I Hear Afar the Song
62. Heralds of Light, Go Ye Forth Mid the Darkness
63. Heralds of Truth, Sound Ye Abroad
64. Holy One, Jesus Our Savior
65. How Calm and Bright the Lovely Morn
66. I Am Happy in My Savior, I Am Singing All the Day
67. [I Am Resolved](#)
68. I Believe in God
69. I Have a Store of All Goodly Things
70. I Hear My Blessed Savior Say, Thy Sins Are All Forgiven
71. I Love the Lord, He Came to Save
72. I Shall Awake When the Trump Shall Sound
73. I Will Not Go Without Thee
74. If I Must Die, O, Let Me Die Reclining
75. In Him We Live
76. [In His Rude Manger-Bed Sleeping](#)
77. In Love for Me the Holy One Enthroned
78. In My Heart the Bells of Gladness
79. In That Summer Land of Beauty
80. In the Country That We Love the Best
81. In the House of Many Mansions
82. In the Kingdom of the Lord
83. In the Land We Love, Home of God's Great Blessing
84. In the Light of God's Truth
85. In the Morning Ere the Busy Day
86. In the Name of Christ, Fling Your Banners Out
87. In the Name of God We're Marching
88. In the Name of Jesus Bow
89. In the Service of My Savior There Is Blessing
90. In the Silence of the Midnight, O My Soul
91. In the Stillness of the Twilight
92. In the Sunday School We're Gathered Once Again
93. Into My Soul Has Come Peace Like a Dove
94. Is There Aught So Lovely as the Sunny Day
95. I've Joy Within Where'er I Go
96. [Jesus Is Calling](#)
97. Jesus Is Calling, Dear One, for Thee
98. Jesus Is Calling, I Hear His Loving Voice
99. Jesus the High and the Holy
100. Jesus, Thou Light Divine
101. Jesus, Thou Merciful Savior
102. Joyful We Come to Zion's Fair Gates
103. Just as Thou Wilt
104. Just on Before Are the Hills of God
105. Leaving It All with Him
106. Light From Heaven Shines on My Way, A
107. Little Boat, Little Boat, Sail Away
108. Lord Be with and Bless Thee, The
109. Lord, We Beseech Thee, Grant Thy Spirit's Power
110. Loud Sounds the Bugle, Clear Comes the Call
111. Love and Help Each Other
112. Lovely, Lovely River, on Thy Way So Free
113. March Boldly On
114. Master Is Calling Thee, Go Forth to the Field, The
115. Messengers of Love and Mercy
116. Murmuring Brooks, the Singing Birds, The
117. My Savior Died upon the Tree
118. Native Land, Our Country Bright
119. O Bright Are the Wavelets on Blue Galilee
120. O, Calvary, Dread Calvary
121. O Come, O Come, Let Us Worship
122. O Country Great, O Country Free
123. O Gently Speak as on We Go
124. O Happy Souls Are We Who Hear
125. O Heavenly Father Hear Our Prayer
126. O Holy Day, O Happy Day
127. O How Pleasant the Way
128. O I Love to Go to Jesus
129. O My Blessed Savior, Guide Me
130. O My Soul, Thy Savior See
131. O Night of Glory, When the Angels Sang
132. O People of the Living God
133. O Praise the Lord, O Praise the Lord, Let Songs
134. O Roses Sweet, O Roses Fair
135. O Savior Mine, So Full, So Free
136. O, Sing of the Love of the Lord
137. O Wonderful Word of Salvation
138. O'er Our Land the Day Is Breaking
139. O'er the Dark and Silent Stream
140. O'er the Meadow and the Mountain
141. O'er the Silent River, Dark and Cold
142. Oft as Returns the Holy Day the Day of Sacred Rest
143. On the Precious Promise of My Savior I'm Resting
144. On the Promise of My Savior
145. On the Western Billows
146. On Thee, My Lord, My Soul Is Stayed
147. [Only Jesus](#)
148. Onward, Onward, Hear the Trumpet Calling
149. Open the Windows of Heaven, O Lord, and Blessings
150. Our Father, While Before Thee
151. Our Native Land We Bring to Jesus
152. Praise of Our Creator, The
153. Praise Ye the Lord with Harp and Voice
154. Praise Ye the Lord, Your Grateful Tribute Bringing
155. [Put on the Whole Armor](#)
156. Refuge Have We When the Storm Sweeps the Skies, A
157. [Resurrection Day, The](#)
158. Rejoice, Rejoice, Ye Nations
159. Scatter Your Many Blessings to the Ones You Hold So Dear
160. See the Dew of Morning on the Blades of Green
161. Seek Ye the Lord While He May Be Found
162. Send Out Thy Light and Thy Truth, Blessed Lord
163. Shepherd So True and Tender
164. Sing Every Clime and Tongue, O Happy World
165. Sing to Jehovah, Sing Ye with Gladness
166. Sky Is Bright, the Heart Is Light, The
167. Soldiers, Are We at the Call of Our King
168. Speed Away
169. Star Divine, That Led the Wise Men
170. Summer Comes at His Decree, The
171. Sweet Are the Promises of the Early Spring
172. Sweet Are the Promises of the Holy Word
173. Sweet Are the Songs of the Wild Birds
174. Sweet Gifts of Love
175. Sweet It Is, O Lord, to Praise
176. Sweet on the Ear Falls a Heavenly Voice
177. Sweet Savior Mine, So Full, So Free
178. Sweetest Song, the Dearest Name, The
179. Take Heart, Weary Toiler, Be of Good Cheer
180. Tell It Again to Me the Story
181. Tell It Out, Tell It Out, Send the Word Abroad
182. Thanks Be to God for All His Mighty Deeds
183. There Is a Marriage of the Great King's Son
184. There Is a Path That Jesus Leads
185. There Is a River Whose Crystal Flood
186. There Is Nothing Like the Goodness
187. There Is One Among the Meek Most Lowly
188. Therefore Watch
189. There's a Battle on Against the Wrong
190. There's a Rising Brightness in the Sky
191. There's Joy in My Heart Today
192. They Are Telling of a Savior
193. Through All the Temple Ringing
194. Through an Enemy's Country We Journey
195. Through the Meadows Where the Sweetest Pasture Grows
196. Thy Lord Hath Visited Thee
197. 'Tis Finished, Was His Dying Cry
198. 'Tis the Sacred Day
199. 'Tis the Savior Pleading, Come, O Come to Me
200. 'Tis the Sweetest Thought
201. To the Blessed Father Now Be Endless Praise
202. To the Lamb That Was Slain and Is Risen Again
203. To Us Has Been Given a Country So Great
204. Today If Ye Will Hear His Voice
205. Trumpet Call of God, The
206. [Unto Him Will I Sing](#)
207. Unto the Lord, unto the Lord
208. Upon the Cross Uplifted High
209. Upon the Sunday Morn, How Sweet
210. Wait Upon God
211. Wait on the Lord, Though Dark Thy Night
212. Watch and Wait for the Time Is Nearing
213. We Are an Army, Grand and Mighty
214. We Are Happy, Always Happy in the Sunday School
215. We Are Soldiers in the Army, We Are Under Marching Orders
216. We Are Waiting Till the Bridegroom Cometh
217. We Come, We Come, We Come to the Sunday School
218. We Have Buckled on the Armor
219. We Praise Thee, O God, in Thy Name We Rejoice
220. We Should Love and Help Each Other
221. We Would Love and Help
222. Week Has Passed Its Busy Round, The
223. [We'll Be There](#)
224. When Bursts the Morning So Clear and So Bright
225. When By the Sea Side Straying
226. When It's Bright Above You
227. When Lord's Day Morning Comes So Fair and Bright
228. When Night Settles Down o'er the Sea
229. When Sunset Is Gilding the Western Hills
230. When the Burning Sun Is Parting
231. When the Christmas Bells Are Pealing Out
232. When the Day Is Breaking and the Night Is Gone
233. When the Shades of Night Are Darkest
234. When the Skies Are Bright I've a Song So Light
235. When the Sky o'er Spreads with Blackness
236. When the Storm Rages High and the Tempest Is Free
237. When the Tide of God's Mercy Comes In
238. When the Troubles of Life Like the Wild Billows Roll
239. When the Winds and Floods Uprising
240. When with the Notes of Spring
241. Where Jesus Calls
242. While Nature Rejoices and We Are So Glad
243. While We're Gathered Here in Happy Throng
244. Who Can Tell the Love of Jesus?
245. Wild Breaks the Storm upon the Deep
246. Wonderful Saving Power of Jesus
247. Would You Have the Things You Ask For?
248. Word of His Grace, The
249. Years of God Are Rolling On, The
250. Young Men, Be Strong the World to Win



**Resolve[d]:** - Fixed purpose of mind; settled determination; resolution. (Webster's 1928)

**Synonyms:** choose, conclude, decide, determine, opt, settle (on or upon), firmness, decisiveness, granite, purposed, stick-to-itiveness, disciplined

**Antonyms:** hesitation, indecision, indecisiveness, vacillation

-----

**James 1:8**

**A double minded man is unstable in all his ways.**



How to be Resolved!  
***Pull Yourself Up  
By Your Bootstraps?***



## John 8:28

Then said Jesus unto them, When ye have lifted up the Son of man, then shall ye know that I am he, and that **I do nothing of myself**; but as my Father hath taught me, I speak these things.

## Romans 7:14-15

For we know that the law is spiritual: but **I am carnal**, sold under sin. For that which I do I allow not: for **what I would, that do I not; but what I hate, that do I.**



# Why do I love God?

## Romans 5:6-8

For when we were yet without strength, in due time Christ died for the ungodly. For scarcely for a righteous man will one die: yet peradventure for a good man some would even dare to die. But God commendeth **his love toward us, in that, while we were yet sinners, Christ died for us.**

## 1 John 4:10,19

Herein is love, not that we loved God, **but that he loved us**, and sent his Son to be the propitiation for our sins.

**:19** We love him, **because he first loved us.**

## Why do I have Faith?

**2 Timothy 2:13** If we believe not, yet **he abideth faithful**: he cannot deny himself.

**1 Corinthians 1:9** **God is faithful**, by whom **ye were called** unto the fellowship of his Son Jesus Christ our Lord.

**2 Peter 1:1** Simon Peter, a servant and an apostle of Jesus Christ, to them that have **obtained like precious faith** with us through the righteousness of God and our Saviour Jesus Christ:

**1 Thessalonians 5:24** **Faithful is he that calleth you, who also will do it.**



# Why am I resolved?

## Ephesians 1:4

According as he hath chosen us in him **before the foundation of the world**, that we should be holy and without blame before him in love:

## Luke 24:46

And said unto them, Thus it is written, and thus it **behoved Christ** to suffer, and to **rise from the dead** the third day: And that repentance and remission of sins should be preached in his name among all nations, beginning at Jerusalem.

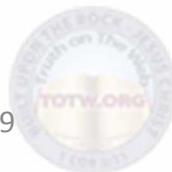

# Why am I resolved?

1 John 5:4-5, 18

For whatsoever is born of God **overcometh the world**: and this is the **victory that overcometh the world**, even our faith. Who is he that **overcometh** the world, but he that believeth that Jesus is the Son of God?

**:18** We know that whosoever is born of God **sinneth not**; but he that is begotten of God keepeth himself, and **that wicked one toucheth him not**.



I

A

M

R

E

S

O

L

V

E

# Why am I resolved?

## Philippians 1:6

Being confident of this very thing, that he which hath begun a good work in you **will perform it until the day of Jesus Christ:**

## 1 Corinthians 10:13

There hath no temptation taken you but such as is common to man: **but God is faithful,** who will not suffer you to be tempted above that ye are able; but will with the temptation also make a **way to escape,** that **ye may be able to bear it.**



# 1 Corinthians 9:24-27

Know ye not that they which **run in a race** run all, but one receiveth the prize? So run, that ye may obtain. And every man that striveth for the mastery is temperate in all things. Now they do it to obtain a corruptible crown; but we an incorruptible. **I therefore so run, not as uncertainly**; so fight I, not as one that **beateth the air**: But I **keep under my body**, and bring it into subjection: lest that by any means, when I have preached to others, I myself should be a castaway.



## Philippians 3:12-14

Not as though I had already attained, either were already perfect: but I follow after, if that I may apprehend that for which also I am apprehended of Christ Jesus. Brethren, **I count not myself to have apprehended**: but this one thing I do, forgetting those things which are **behind**, and **reaching forth** unto those things which are before, **I press toward the mark for the prize of the high calling of God in Christ Jesus.**



## Revelation 2:7

He that hath an ear, let him hear what the Spirit saith unto the churches; **To him that overcometh** will I give to eat of the tree of life, which is in the midst of the paradise of God. *(Rev 2:11,17,26,3:5,12,21,21:7)*

## Luke 6:46

**And why call ye me, Lord, Lord, and do not the things which I say?**



## Luke 9:62

And Jesus said unto him, **No man**, having put his hand to the plough, and looking back, **is fit for the kingdom of God.**

## Matthew 7:21-23

**Not every one** that saith unto me, Lord, Lord, shall enter into the kingdom of heaven; but he that doeth the will of my Father which is in heaven. Many will say to me in that day, Lord, Lord, have we not prophesied in thy name? and in thy name have cast out devils? and in thy name done many wonderful works? And then will I profess unto them, I never knew you: **depart from me, ye that work iniquity.**



I  
A  
M  
R  
E  
S  
O  
L  
V  
E  
D

# RCA





# Root Cause Analysis

## What Is Root Cause Analysis (RCA)?

Root Cause Analysis (RCA) is a useful popular tool that helps determine the basic, underlying cause of a problem through a series of specific steps. A factor is considered a root cause if its removal from the problem-fault-sequence prevents the final undesirable event from recurring.

When Should Root Cause Analysis be Performed?

- When human errors occur during a workflow process
- When performance is below standard
- When equipment failures or adverse events occur during certain work processes

The successful application of the determination of the root cause should ultimately result in the elimination of the problem.

### Steps of RCA

Step 1:  
Identify  
the Problem

Step 2:  
Select Team

Step 3:  
Collect Data

Step 4:  
Identify  
Possible Factors

Step 5:  
Identify  
Root Cause(s)

Step 7:  
Monitor and  
Assess Results

Step 6:  
Define and  
Implement an  
Action Plan

**SIX**  
SIGMA

www.6sigma.com



# U.S.

## Oil refinery explosion kills at least 14

**Blast felt several miles from plant in Texas City, Texas**

Thursday, March 24, 2005 Posted: 9:12 AM EST (1412 GMT)

**TEXAS CITY, Texas (CNN) -- At least 14 people died and more than 70 others were injured in an explosion that ripped through a BP oil refinery in southeastern Texas on Wednesday, a company spokesman said.**

The fire sent huge plumes of smoke high into the air, and the blaze took nearly two hours to extinguish, Bill Stephen said.

"We believe it's 14 people, but we will wait for official confirmation from the medical examiner," he told reporters.

Stephen added that it was possible the number of dead could rise as emergency crews were continuing to search through



**Image:**



# ISOM (Isomerization) Process

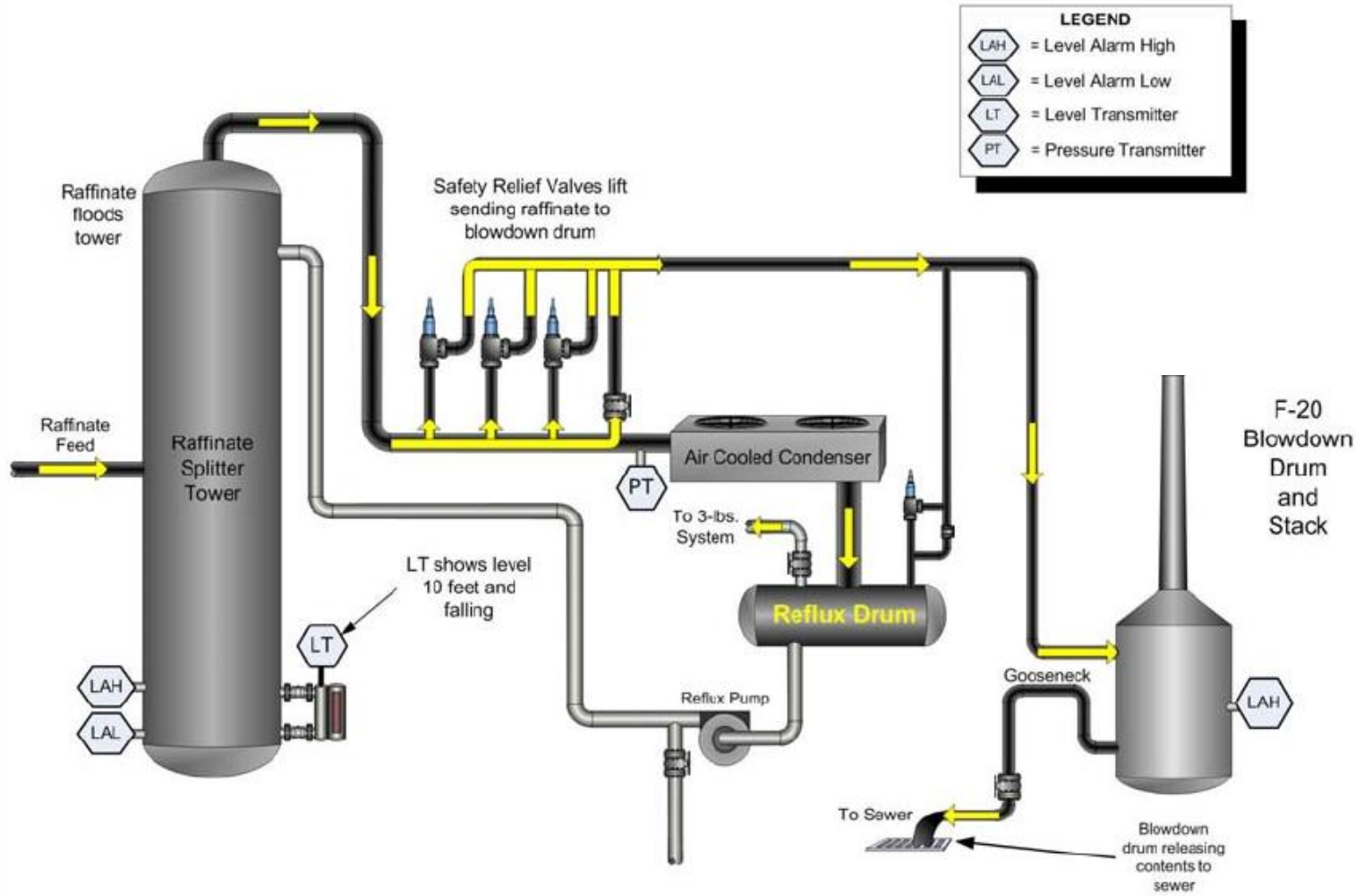

I  
A  
M  
R  
E  
S  
O  
L  
V  
E  
D

# ISOM (Isomerization) Process

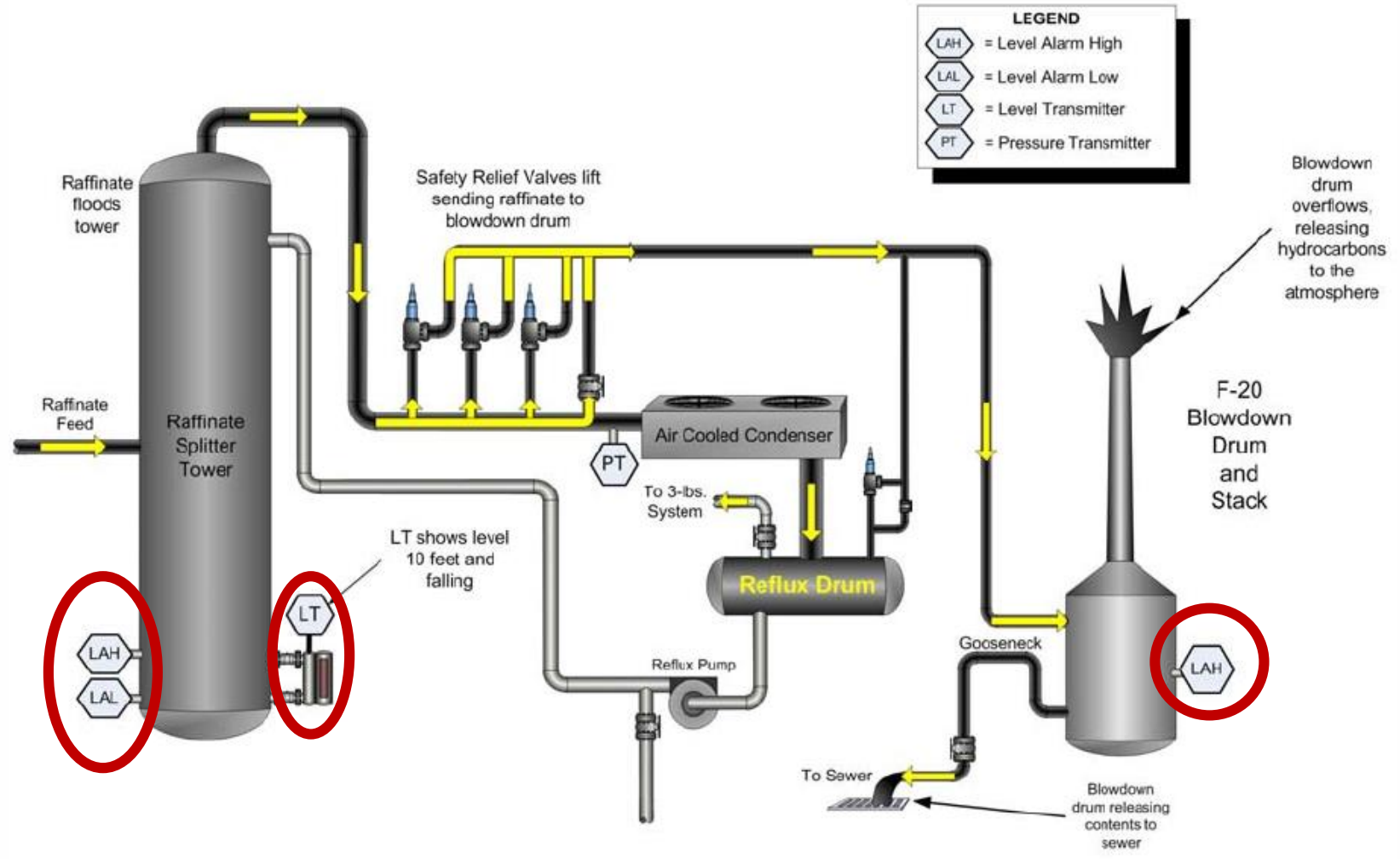



## Isaiah 59:1-3

Behold, the LORD'S hand is not shortened, that it cannot save; neither his ear heavy, that it cannot hear: **But your iniquities have separated between you and your God, and your sins have hid his face from you, that he will not hear.** For your hands are defiled with blood, and your fingers with iniquity; your lips have spoken lies, your tongue hath muttered perverseness.

## 1 John 3:8

He that committeth sin is **of the devil**; for the devil sinneth from the beginning. For this purpose the Son of God was manifested, that he might destroy the works of the devil.



I  
A  
M  
R  
E  
S  
O  
L  
V  
E  
D



I  
A  
M  
R  
E  
S  
O  
L  
V  
E  
D

**NO!!!**

**NOT EVEN FOR A SECOND!  
IN THIS BE**

**100%**

**RESOLVED!**





## James 1:13-15

Let no man say when he is tempted, **I am tempted of God**: for God cannot be tempted with evil, neither tempteth he any man: But every man is tempted, **when he is drawn away of his own lust, and enticed**. Then when lust hath conceived, it **bringeth forth sin**: and sin, when it is finished, **bringeth forth death**.



## 1 Corinthians 2:15

But he that is spiritual judgeth all things, yet **he himself is judged of no man.**

## 1 Corinthians 11:28-31

But let a man **examine himself**, and so let him eat of that bread, and drink of that cup. For he that eateth and drinketh unworthily, eateth and drinketh damnation to himself, not discerning the Lord's body. **For this cause many are weak and sickly among you, and many sleep.** For if we would **judge ourselves, we should not be judged.**



## 2 Corinthians 13:5

**Examine yourselves, whether ye be in the faith**; prove your own selves. Know ye not your own selves, how that **Jesus Christ is in you**, except ye be reprobates?

## Psalms 19:12-14

Who can understand his errors? cleanse thou me from **secret faults**. Keep back thy servant also from **presumptuous sins**; let them not have dominion over me: then shall I be upright, and I shall be innocent from **the great transgression**. Let the words of my mouth, and the meditation of my heart, be acceptable in thy sight, O LORD, my strength, and my redeemer.



## Psalms 1:1-3

Blessed is the man that walketh not in the counsel of the ungodly, nor standeth in the way of sinners, nor sitteth in the seat of the scornful. But his delight is in the **law of the LORD**; and in his law doth he meditate day and night. And he shall be like a **tree planted** by the rivers of water, that bringeth forth his fruit in his season; **his leaf also shall not wither; and whatsoever he doeth shall prosper.**

## Psalms 119:105

Thy word is a lamp unto **my feet**, and a light unto **my path.**



## James 4:7

**Submit** yourselves therefore to God. **Resist the devil**, and he will flee from you.

## Ephesians 6:10-11,18

Finally, my brethren, **be strong in the Lord**, and in the **power of his might**. Put on the **whole armour of God**, that ye may be **able to stand** against the wiles of the devil.

**:18 Praying always** with all prayer and supplication **in the Spirit**, and watching thereunto with all perseverance and supplication for all saints;



## **Proverbs 9:6**

Forsake the foolish, and live; and go in the way of understanding.

## **Proverbs 14:7**

Go from the presence of a foolish man, when thou perceivest not in him the lips of knowledge.

## **Proverbs 22:24–25**

Make no friendship with an angry man; and with a furious man thou shalt not go: Lest thou learn his ways, and get a snare to thy soul.

## **1 Corinthians 15:33**

Be not deceived: evil communications corrupt good manners.



## **Galatians 5:23**

Meekness, temperance: against such there is no law.

## **Titus 2:11–14**

For the grace of God that bringeth salvation hath appeared to all men, Teaching us that, denying ungodliness and worldly lusts, we should live soberly, righteously, and godly, in this present world; Looking for that blessed hope, and the glorious appearing of the great God and our Saviour Jesus Christ; Who gave himself for us, that he might redeem us from all iniquity, and purify unto himself a peculiar people, zealous of good works.



## **Romans 13:14**

But put ye on the Lord Jesus Christ, and make not provision for the flesh, to fulfil the lusts thereof.

## **Psalms 141:4**

Incline not my heart to any evil thing, to practise wicked works with men that work iniquity: and let me not eat of their dainties.

## **Proverbs 23:2**

And put a knife to thy throat, if thou be a man given to appetite.





## Matthew 18:7-9

Woe unto the world because of offences! for it must needs be that offences come; but woe to that man by whom the offence cometh! Wherefore if thy hand or thy foot offend thee, cut them off, and cast them from thee: it is better for thee to enter into life halt or maimed, rather than having two hands or two feet to be cast into everlasting fire. And if thine eye offend thee, pluck it out, and cast it from thee: it is better for thee to enter into life with one eye, rather than having two eyes to be cast into hell fire.



## **Psalms 101:3**

I will set no wicked thing before mine eyes: I hate the work of them that turn aside; it shall not cleave to me.

## **Job 31:1**

I made a covenant with mine eyes; why then should I think upon a maid?

## **Proverbs 15:1**

A soft answer turneth away wrath: but grievous words stir up anger.



## Luke 9:23-24

And he said to them all, If any man will come after me, let him deny himself, and take up his cross daily, and follow me. For whosoever will save his life shall lose it: but whosoever will lose his life for my sake, the same shall save it.



## Philippians 4:10-13

But I rejoiced in the Lord greatly, that now at the last your care of me hath flourished again; wherein ye were also careful, but ye lacked opportunity. Not that I speak in respect of want: for I have learned, in whatsoever state I am, therewith to be content. **I know both how to be abased, and I know how to abound:** every where and in all things I am instructed both to be full and to be hungry, both to abound and to suffer need. **I can do all things through Christ which strengtheneth me.**



## James 4:13-17

Go to now, ye that say, To day or to morrow we will go into such a city, and continue there a year, and buy and sell, and get gain:

Whereas ye know not what shall be on the morrow. For what is your life? It is even a vapour, that appeareth for a little time, and then vanisheth away. For that ye ought to say,

**If the Lord will, we shall live, and do this, or that.** But now ye rejoyce in your boastings: all such rejoicing is evil. Therefore to him that knoweth to do good, and doeth it not, to him it is sin.



## 1 Peter 4:11

**If any man speak**, let him speak as the **oracles of God**; if any man minister, let him do it as of the ability which **God giveth**: that **God in all things may be glorified through Jesus Christ**, to whom be praise and dominion for ever and ever. Amen.

I  
A  
M  
R  
E  
S  
O  
L  
V  
E  
D



## Ecclesiastes 5:5-7

Better is it that thou shouldest not vow, than that thou shouldest vow and not pay. **Suffer not thy mouth to cause thy flesh to sin;** neither say thou before the angel, **that it was an error:** wherefore should God be angry at thy voice, and destroy the work of thine hands? For in the multitude of dreams and many words there are also divers vanities: but fear thou God.



## 2 Corinthians 1:15-17

And in this confidence I was minded to come unto you before, that ye might have a second benefit; And to pass by you into Macedonia, and to come again out of Macedonia unto you, and of you to be brought on my way toward Judaea. When I therefore was thus minded, did I use lightness? or the things that I purpose, **do I purpose according to the flesh**, that with me there should be yea yea, and nay nay?





## Hebrews 12:1-2

Wherefore seeing we also are compassed about with so great a cloud of witnesses, let us **lay aside every weight**, and **the sin which doth so easily beset us**, and let us **run with patience the race that is set before us**,

### Looking unto Jesus

the **author and finisher of our faith**; who for the joy that was set before him endured the cross, despising the shame, and is set down at the right hand of the throne of God.



## 1 John 2:1-2

My little children, these things write I unto you, **that ye sin not**. And

**If**

any man sin,

**we have an advocate**

with the Father,

**Jesus Christ the righteous**

And he is the propitiation for our sins: and not for ours only, but also for the sins of the whole world.



## Romans 8:1

There is therefore now **no condemnation to them which are in Christ Jesus**, who walk not after the flesh, but after the Spirit.

## Romans 8:9-11

But ye are not in the flesh, but in the Spirit, if so be that the Spirit of God dwell in you. Now if any man have not the Spirit of Christ, he is none of his. And **if Christ be in you, the body is dead** because of sin; but **the Spirit is life** because of righteousness. But if the Spirit of him that raised up Jesus from the dead dwell in you, he that raised up Christ from the dead **shall also quicken your mortal bodies by his Spirit** that dwelleth in you.



## 1 Peter 1:13-16

Wherefore **gird up the loins of your mind**, be sober, and **hope to the end for the grace** that is to be brought unto you at the revelation of Jesus Christ; As **obedient children**, not fashioning yourselves according to the former lusts in your ignorance: But as he which hath called you is holy, **so be ye holy in all manner of conversation**; Because it is written, Be ye holy; for I am holy.



## 1 Peter 5:6-10

Humble yourselves therefore under the mighty hand of God, that he may exalt you in due time: Casting all your care upon him; for he careth for you. **Be sober, be vigilant; because your adversary the devil, as a roaring lion, walketh about, seeking whom he may devour:** Whom **resist stedfast in the faith**, knowing that the same afflictions are accomplished in your brethren that are in the world. But the God of all grace, who hath called us unto his eternal glory by Christ Jesus, after that ye have suffered a while, **make you perfect, stablish, strengthen, settle you.**



## Hebrews 5:5a

So also **Christ** glorified not himself to be made an high priest;

## Hebrews 5:8-9

Though he [*Christ*] were a Son, yet **learned he obedience** by the things which he suffered; And **being made perfect, he became** the author of eternal salvation unto all them that obey him;



## 2 Corinthians 10:3-5

For though we walk in the flesh, **we do not war after the flesh**: (For the weapons of our warfare are not carnal, but mighty through God to the pulling down of strong holds;) Casting down imaginations, and every high thing that exalteth itself against the knowledge of God, **and bringing into captivity every thought to the obedience of Christ**;



## Philippians 4:6-9

Be careful for nothing; but in every thing by prayer and supplication with thanksgiving let your requests be made known unto God. And the peace of God, which passeth all understanding, shall keep your hearts and minds through Christ Jesus. Finally, brethren, whatsoever things are true, whatsoever things are honest, whatsoever things are just, whatsoever things are pure, whatsoever things are lovely, whatsoever things are of good report; if there be any virtue, and if there be any praise, think on these things. Those things, which ye have both learned, and received, and heard, and seen in me, do: **and the God of peace shall be with you.**





ENJOY THE REST OF  
THE SABBATH

ENJOY THE REST OF  
THE SABBATH

ENJOY THE REST OF  
THE SABBATH

ENJOY THE REST OF  
THE SABBATH



**TRUTH ON THE  
WEB MINISTRIES**

**[WWW.TOTW.ORG](http://WWW.TOTW.ORG)**

EPH 6:17 AND TAKE...THE SWORD OF THE  
SPIRIT WHICH IS THE WORD OF GOD  
A CHURCH OF GOD IN WOODSTOCK, ILLINOIS

