

Think BIBLICALLY

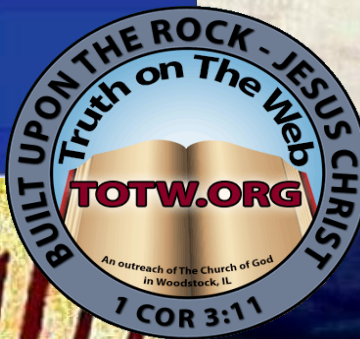

RENEW

your mind
Romans 12:2

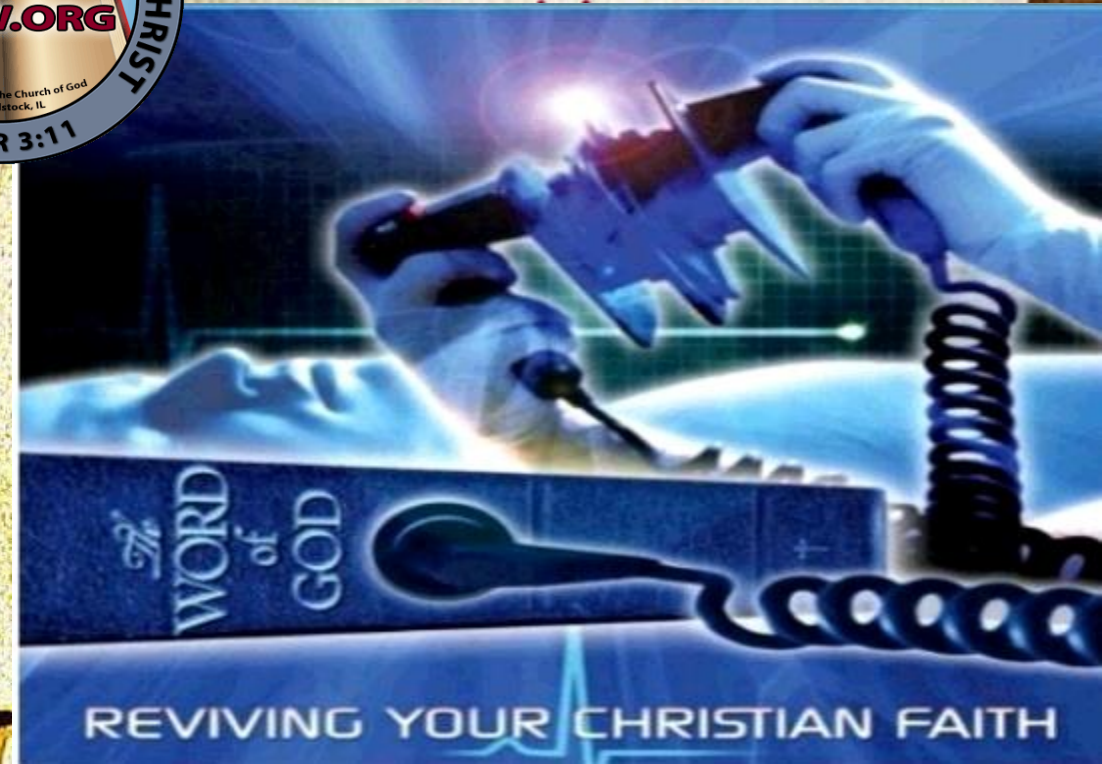
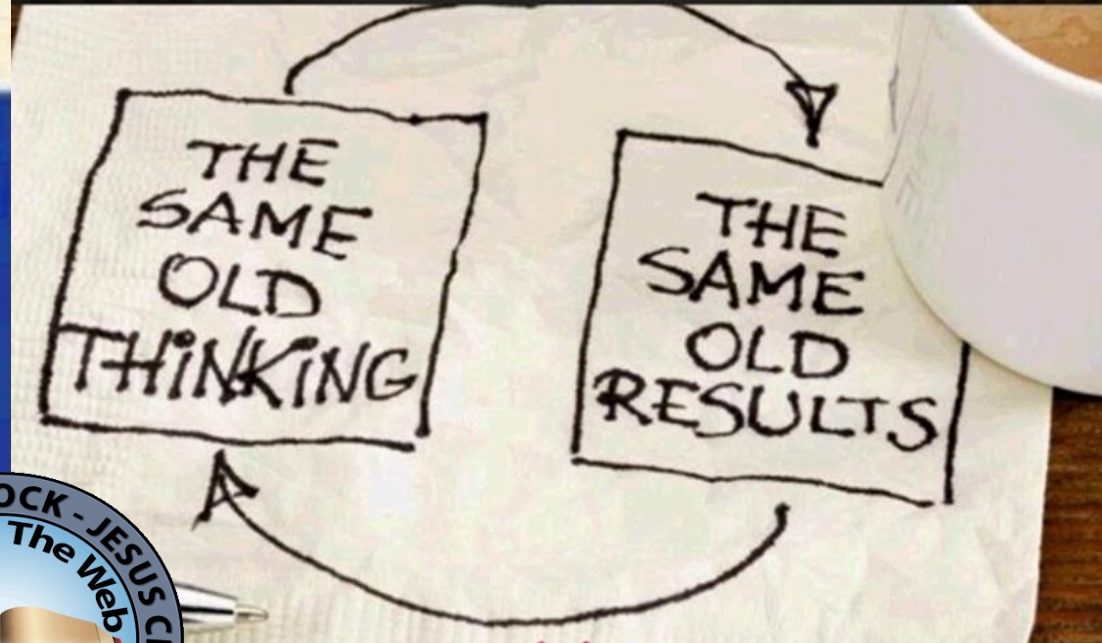

Dwelling Together In Unity

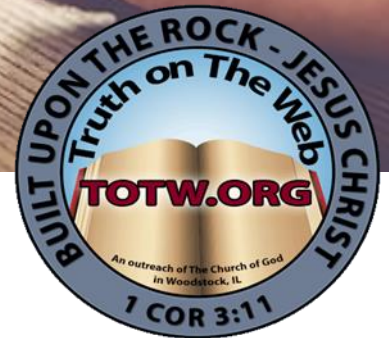

Matthew 19:3-4 The Pharisees also came unto Him, tempting Him, and saying unto Him, Is it lawful for a man to put away his wife for every cause? And He answered and said unto them, Have ye not read, that He which made *them* at the beginning made them male and female,

Matthew 19:5-6 And said, For this cause shall a man leave father and mother, and shall cleave to his wife: and they twain shall be one flesh? Wherefore they are no more twain, but one flesh. What therefore God hath joined together, let not man put asunder.

Matthew 19:7-8 They say unto Him, Why did Moses then command to give a writing of divorcement, and to put her away? He saith unto them, Moses **because of the hardness of your hearts suffered you to put away your wives:** but from the beginning it was not so.

Why do marriages split?

* Wrong Person / Too Young

* Wrong Person / Too Young

* Grew apart / Fell out of love

* Wrong Person / Too Young

* Grew apart / Fell out of love

* Arguments / Conflicts

- * Wrong Person / Too Young
- * Grew apart / Fell out of love
 - * Arguments / Conflicts
 - * Financial Strains
 - * Lack of Intimacy

- * Wrong Person / Too Young
- * Grew apart / Fell out of love
 - * Arguments / Conflicts
 - * Financial Strains
 - * Lack of Intimacy
 - * Adultery



- * Wrong Person / Too Young
- * Grew apart / Fell out of love
- * Arguments / Conflicts
 - * Financial Strains
 - * Lack of Intimacy
 - * Adultery

Ephesians 5:22-33 Wives, submit yourselves unto your own husbands, as unto the Lord. For the husband is the head of the wife, even as Christ is the head of the church: and He is the Saviour of the body. Therefore as the church is subject unto Christ, so *let* the wives *be* to their own husbands in every thing.

Husbands, love your wives, even as Christ also loved the church, and gave Himself for it; That He might sanctify and cleanse it with the washing of water by the word, That He might present it to Himself a glorious church, not having spot, or wrinkle, or any such thing; but that it should be holy and without blemish. So ought men to love their wives as their own bodies. He that loveth his wife loveth himself. For no man ever yet hated his own flesh; but nourisheth and cherisheth it, even as the Lord the church: For we are members of His body, of His flesh, and of His bones. For this cause shall a man leave his father and mother, and shall be joined unto his wife, and they two shall be one flesh. This is a great mystery: but I speak concerning Christ and the church.

Nevertheless let every one of you in particular so love his wife even as himself; and the wife see that she reverence *her* husband.

1 Corinthians 12:27 Now ye are the body of Christ, and members in particular.

Romans 12:5 So we, being many, are one body in Christ, and every one members one of another.

John 17:11 And now I am no more in the world, but these are in the world, and I come to Thee. Holy Father, keep through Thine own name those whom Thou hast given Me, **that they may be one, as We are.**

**Is there doctrine that you treasure
more than unity?**

John 17:20-23 Neither pray I for these alone, but for them also which shall believe on Me through their word; **That they all may be one; as Thou, Father, art in Me, and I in Thee, that they also may be one in Us:** that the world may believe that Thou hast sent Me. And the glory which Thou gavest Me I have given them; **that they may be one, even as We are one: I in them, and Thou in Me, that they may be made perfect in one;** and that the world may know that Thou hast sent Me, and hast loved them, as Thou hast loved Me.

Why do churches split?

Calendar Issues

Hebrew Names

Personal Dislikes / Disagreements

Leadership Issues

???



Hebrew Names?

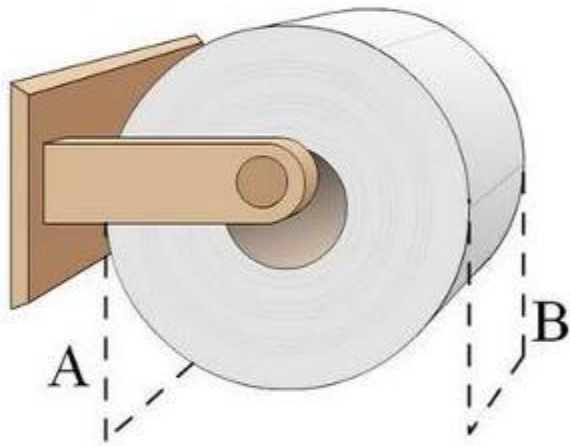

or



THE GREAT

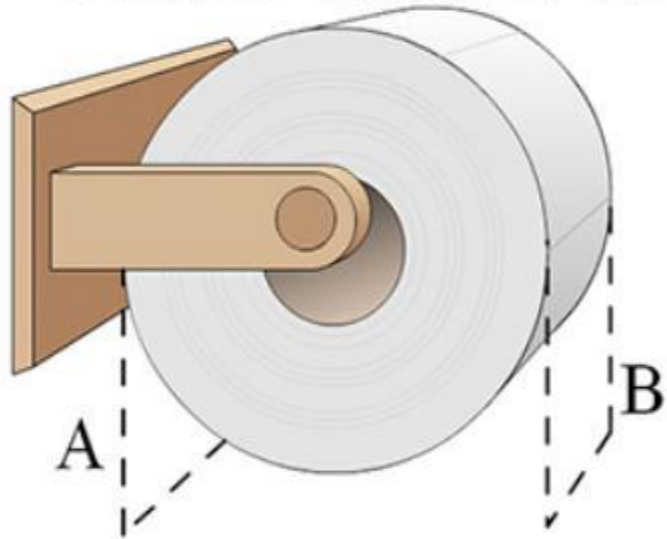

DEBATE

Disputable matters
wherein the Scripture
does not require
adherence one way
or the other) . They
do not apply to
requirements of law.

i.e., Romans 14 & 15

Hebrew Names?

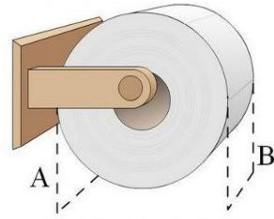

or



Romans 14-ism?

Him that is weak in the faith receive ye, but not to doubtful disputations. For one believeth that he may use all languages to speak of our Creator: another, who is weak, useth only Hebrew. Let not him that useth all languages despise him that useth not, but Hebrew; and let not him which useth not but Hebrew judge him that useth all: for God hath received him. Who art thou that judgest another man's servant? to his own master he standeth or falleth. Yea, he shall be holden up: for God is able to make him stand.

Why should churches split?



Romans 16:17-18 Now I beg you, brothers, look out for those who are causing the divisions and occasions of stumbling, contrary to the doctrine which you learned, and turn away from them. For those who are such don't serve our Lord, Jesus Christ, but their own belly; and by their smooth and flattering speech, they deceive the hearts of the innocent.

Proverbs 18:1-2 Through desire a man, having separated himself, seeketh *and* intermeddleth with all wisdom. A fool hath no delight in understanding, but that his heart may discover itself.

Proverbs 18:1-2 Whoever isolates himself seeks his own desire; he breaks out against all sound judgment. A fool takes no pleasure in understanding, but only in expressing his opinion.

Where do wars and fightings come from?

James 4:1-3 Where do wars and fightings among you come from? Don't they come from your pleasures that war in your members? You lust, and don't have. You kill, covet, and can't obtain. You fight and make war. You don't have, because you don't ask. You ask, and don't receive, because you ask with wrong motives, so that you may spend it for your pleasures.

But about the feuds and struggles that exist among you—where do you suppose they come from? Can't you see that they arise from conflicting passions within yourselves? You crave for something and don't get it, you are jealous and envious of what others have got and you don't possess it yourselves. Consequently in your exasperated frustration you struggle and fight with one another. You don't get what you want because you don't ask God for it. And when you do ask He doesn't give it to you, for you ask in quite the wrong spirit—you only want to satisfy your own desires.

James 3:13-16 Are there some wise and understanding men among you? Then your lives will be an example of the humility that is born of true wisdom. But if your heart is full of rivalry and bitter jealousy, then do not boast of your wisdom—don't deny the truth that you must recognise in your inmost heart. You may acquire a certain superficial wisdom, but it does not come from God—it comes from this world, from your own lower nature, even from the devil. For **wherever you find jealousy and rivalry you also find disharmony and all other kinds of evil.**

1 Corinthians 3:3-4 For ye are yet carnal: for whereas there is among you envying, and strife, and divisions, are ye not carnal, and walk as men? For while one saith, I am of Paul; and another, I am of Apollos; are ye not carnal?

1 Corinthians 1:10 Now I beseech you, brethren, by the name of our Lord Jesus Christ, that ye all speak the same thing, and that there be no divisions among you; but that ye be perfectly joined together in the same mind and in the same judgment.

Judge Righteous Judgement

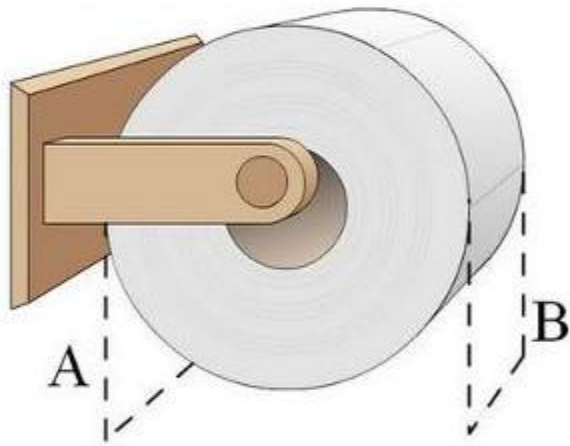

or



Philippians 3:15-16 Let us therefore, as many as be perfect, be thus minded: and if in any thing ye be otherwise minded, God shall reveal even this unto you. Nevertheless, whereto we have already attained, let us walk by the same rule, let us mind the same thing.

Philippians 2:1-7 If *there be* therefore any consolation in Christ, if any comfort of love, if any fellowship of the Spirit, if any bowels and mercies, Fulfil ye my joy, that ye be likeminded, having the same love, *being* of one accord, of one mind. *Let nothing be done* through strife or vainglory; but in lowliness of mind let each esteem other better than themselves. Look not every man on his own things, but every man also on the things of others. Let this mind be in you, which was also in Christ Jesus: Who, being in the form of God, thought it not robbery to be equal with God: But made himself of no reputation, and took upon him the form of a servant, and was made in the likeness of men:

Ephesians 4:1-3 I therefore, the prisoner of the Lord, beseech you that ye **walk worthy of the vocation wherewith ye are called**, With all lowliness and meekness, with longsuffering, forbearing one another in love; Endeavouring to keep the unity of the Spirit in the bond of peace.

Mark 10:9 What therefore God hath joined together, let not man put asunder.

Think BIBLICALLY

